

Milling Equipment for Versatile Uses

VERTICAL RICE WHITENER

VTA5AA-TA / 10AB-TA / 15AB-T



VTA10AB-TA

SATAKE CORPORATION

The design concept of the Satake Vertical Rice Whitener, VTA series, is the result of the accumulation of many years of vertical milling engineering expertise. This machine has incorporated all of the most modern techniques of vertical milling and has been proven to be "The Machine" in many major mills throughout the United States and Europe, and in Asian countries such as Thailand and India. The versatility of the VTA for milling all degrees of milled rice has given the industry the ideal machine.

FEATURES:

1. Higher Milling Yield and Fewer Broken:

Evenly milled, higher yield rice with fewer broken and minimum moisture loss is obtained due to the adoption of the newly developed, state-of-the-art milling chamber.

2. Easy Operation:

The required whiteness is easily obtained by the adjustment of the discharge weight. An automatic milling degree controller is also available as an option.

3. Easy Replacement of Parts:

The abrasive rolls are easily withdrawn from the top of the unit, because the cantilevered main shaft design makes a bearing at the top of the machine unnecessary. The screens are of a "lift-away" design, which makes screen changes quick and easy without having to remove the frame from the machine. All other parts are easily accessible and readily changeable.

4. Minimum Bran Residue Inside Machine:

In the section below the milling chamber, there is a bran rotor valve which assists in removing bran from the machine.

※Satake VTA is also applicable for other grains, e.g. barley, oats, sorghum, wheat etc. Please contact your Satake Representative office for details.

VERTICAL RICE WHITENER

Specifications

Model		VTA5AA-TA	VTA10AB-TA	VTA15AB-T
Input Capacity (t/h)	Non-Parboiled	2~3	5~6	6~8
	Parboiled	1.5~2.5	4~5	5~6
Motor (kW)		22~30 (4P)	45~55 (6P)	55~75 (6P)
Required Air Volume (m ³ /min)		30	50	60
Static Pressure (kpa)		0.8~1.0	1.0~1.5	1.0~1.5

*Input capacity is depending on the variety and type of material

Dimensions

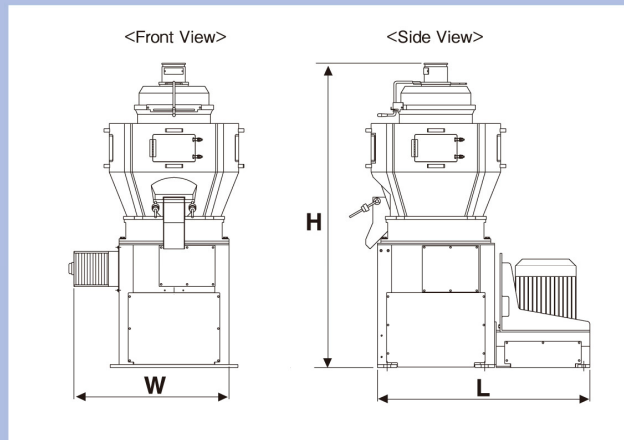

Model	W (mm)	L (mm)	H (mm)	Weight (kg) *1
VTA5AA-TA	1,052	1,719	2,309	900
VTA10AB-TA	1,235	1,694	2,148	1,300
VTA15AB-T	1,294	1,731	2,150	1,700

*1 Approximate Shipping Weight (without motor)

All Satake products are the subject of continuous development and, as a result, their specification may change and differ in detail from those shown.

SATAKE CORPORATION

Head Office

2-30, Saijo-Nishihonmachi,
Higashi-Hiroshima, 739-8602, Japan
Tel : +81-82-420-8560/8539
Fax : +81-82-420-0865
e-mail : kg-hiroshima@satake-japan.co.jp
URL : www.satake-japan.co.jp

UK Division

P.O.Box 53, Bredbury, Stockport,
Cheshire, SK6 2FG, England
Tel : +44-161-406-3800
Fax : +44-161-406-3801
e-mail : sales@satake.co.uk
URL : www.satake.co.uk

Yangon Office

No.32, Pyay Road,
Hlaing Township, Yangon
Myanmar
Tel : +95-1-525077
Fax : +95-1-512742
e-mail : ygsatake@mptmail.net.mm

Beijing Office

Room 4405, Building No.2,
No.208, 2nd Zone, Lize
Zhongyuan, Chaoyang District,
Beijing, People's Republic of China
Tel : +86-10-8454-0146
Fax : +86-10-8454-0145

SATAKE USA INC.

10905 Cash Road,
Stafford, Texas 77477 U.S.A.
Tel : +1-281-276-3600
Fax : +1-281-494-1375
e-mail : rice@satake-usa.com
URL : www.satake-usa.com

SATAKE (CANADA) INC.

5100 Fallingbrook Drive
Mississauga, Ontario, L5V
1S7, Canada
Tel : +1-905-858-0791
Fax : +1-905-858-0957
e-mail : satakecanada@rogers.com

SATAKE AMERICA LATINA LTDA.

Rua Xavantes, 155-Bairro
Atradores, CEP 89203-210,
Joinville, Santa Catarina, Brazil
Tel : +55-47-438-0413
Fax : +55-47-438-7932
e-mail : ricardo@satake.com.br

SATAKE INDIA ENGINEERING PVT. LTD.

4th Floor, Tower-1, HB Twin Towers, A2,
3, 4-Netaji Subhash Place, Wazirpur
District Centre, New Delhi, 110034, India
Tel : +91-11-47062626
Fax : +91-11-47062624
e-mail : satake@del2.vsnl.net.in

SATAKE (THAILAND) CO., LTD.

133 Moo 5, Bangkadi Industrial Park,
Tivanon Road, Patumthani 12000, Thailand
Tel : +66-2-501-1180
Fax : +66-2-501-1188
e-mail : satake@asia.com
URL : http://www.satake.th.com/

SATAKE INTERNATIONAL BANGKOK CO., LTD.

888/152 Mahatun Plaza Bld. 15th Floor
Ploenchit Rd., Lumpini Pathumwan
Bangkok 10330, THAILAND
Tel : +66-2-651-5845
Fax : +66-2-651-5848
e-mail : satake@asia.com

SATAKE MANUFACTURING (SUZHOU) CO., LTD.

Jin Feng Road, Suzhou
New District, Suzhou City,
Jiangsu Province P.R.China
Tel : +86-512-6536-8225
Fax : +86-512-6536-3004
e-mail : satake@satake.cn

SATAKE AUSTRALIA PTY. LTD.

23-25 Marigold Street, Revesby,
NSW 2212 Australia
Tel : +61-2-9774-1155
Fax : +61-2-9774-1248
e-mail : sataus@ozemail.com.au
URL : www.satake.com.au

SATAKE CORPORATION has
obtained ISO 9001 and ISO
14001 certification.
These international standards
for management systems
ensure Satake will continue to
provide high quality products
and services.

ISO 9001 Certification
(Quality Management Systems)

ISO 14001 Certification
(Environmental Management Systems)