

Polishing Machine for Improved Product Quality

MILLING POLISHER

KB100PA-T



KB100PA-T

The Satake Milling Polisher KB100PA-T cleans the surface of rice, significantly enhancing the quality of finished products. The machine has achieved an excellent reputation in many countries for its high performance and for the innovations which have been incorporated over the past 30 years.

FEATURES:

1. Increased capacity

Enhanced conveying and polishing systems provide the highest capacity of KB series without much increasing installation space.

2. Improves rice quality

Greater mist-adding capacity controls rice temperature during polishing and allows uniform removal of bran, producing brilliantly white, shiny rice.

3. Easy maintenance

A redesigned main body side cover greatly improves maintenance efficiency.

4. Easy operation

The flow control dial is located on the upper part of the front panel for easy access and operation.

5. Broad applicability

Use in combination with other Satake milling equipment to process a wide variety of rice, including GABA and parboiled rice.

MILLING POLISHER

Specifications

Model	KB100PA-T
Required Power (kW)	90
Input Capacity (t/h)*	8~10
Required Air Volume (m ³ /min)	90
Required Static Pressure (kPa)	-1.5~2.0
Net Weight (kg)	1,147

* Input capacity depends on material.

Dimensions

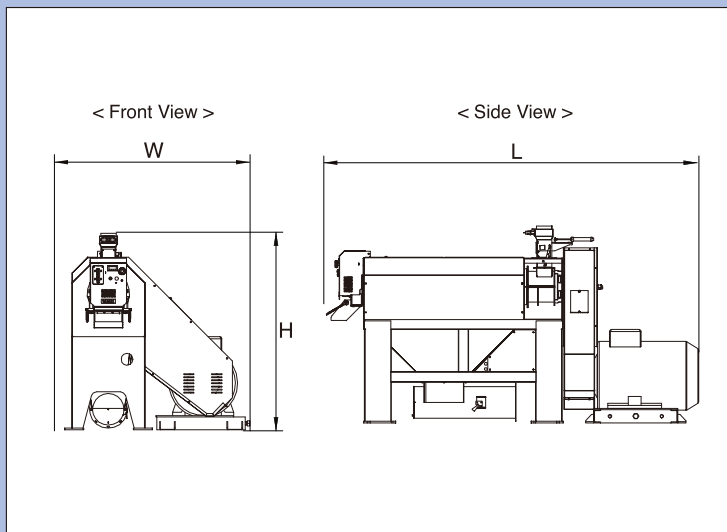

Model	W(mm)	L(mm)	H(mm)
KB100PA-T	1,790	3,600	1,900

* It is recommended to install a Rotary Sifter just before the machine to remove broken grains and branny material for the following cases:

- a- When processing white rice to produce the best-polished rice.
- b- When using the machine as a rice whitening machine.

All Satake products are the subject of continuous development and, as a result, their specification may change and differ in detail from those shown.

SATAKE CORPORATION

Head Office
2-30 Saijo Nishihonmachi,
Higashi-Hiroshima-shi, Hiroshima-ken,
739-8602, Japan
URL : www.satake-group.com

Korea Branch
Alpha mighty Dunsan Building, 13F,
229, Daedeck-daero, Seo-gu, 35229
Thailand
URL : www.satake-group.com

SATAKE USA INC.
10900 Cash Road,
Stafford, Texas, 77477, U.S.A.
URL : www.satake-usa.com

SATAKE AMERICA LATINA LTDA.
Rua Xavantes, 155-Pav. 20, Bairro
Atiradores, CEP 89203-210, Joinville,
Santa Catarina, Brazil
URL : www.satake.com.br/

SATAKE EUROPE LTD.
P.O. Box 53, Horsfield Way, Bredbury
Industrial Park, Bredbury, Stockport,
Cheshire, SK6 2SU, U.K.
URL : www.satake-europe.com

SATAKE INDIA ENGINEERING PVT. LTD.
4th Floor, Tower-1, HB Twin Towers, A2,
3, 4, Netaji Subhash Place, Wazirpur
District Centre, New Delhi, 110034, India
URL : www.satakeindia.com/

SATAKE (THAILAND) CO., LTD.
133.134 Moo 5, Bangkadi, Mueang
Pathum Thani, Pathum Thani 12000,
Thailand
URL : www.sataketh.com

SATAKE ASIA CO., LTD.
888/84 Mahatun Plaza Bld., 8th Floor,
Ploenchit Rd., Lumpini, Pathumwan,
Bangkok, 10330, Thailand
URL : www.sataketh.com

PT. SATAKE GOBEL INDONESIA
Gedung Surabaya Bumi Mandiri,
Lantai 9, Jalan Jenderal Basuki
Rachmat Nomor 129-137, Unit 905 B,
Indonesia

SATAKE MANUFACTURING (SUZHOU) CO., LTD.
229 Jin Feng Road, Suzhou New
District, Suzhou, Jiangsu Province,
215129, China
URL : www.satake.cn/

SATAKE AUSTRALIA PTY. LTD.
15 Leland Street, Penrith, N.S.W.,
2750, Australia
URL : www.satake.com.au

ISO 9001 Certification
(Quality Management Systems)

ISO 14001 Certification
(Environmental Management Systems)

SATAKE CORPORATION has obtained ISO9001 and ISO14001 certification. These international standards for management systems ensure Satake will continue to provide high quality products and services.